

AC-DC Converter

**POWER
SOLVE**

PAK450 Series 450W Active PFC Single Output

www.powersolve.com.tw

Features

- Universal AC Input with active PFC
- High Efficiency up to 93%
- +5V/0.3A Auxiliary Output
- 150% Peak Load Capability
- 1U profile, High Power Density
- Built-in Constant Current Limiting Circuit
- Power OK signal (Power good, logic low)
- Remote ON/OFF, Remote Sense function
- OVP, OLP, OTP, SCP, Fan Failure Protections



Electrical Specification

Input Voltage	90-264VAC full range, 47-63Hz / 127-370VDC
Power Factor	0.98 at 230VAC / 0.99 at 115VAC at full load
AC Input Current (typ.)	4.5A at 115VAC / 2.2A at 230VAC
Inrush Current	27A at 115VAC / 54A at 230VAC
Leakage Current	<1mA at 240VAC
Output Voltage	See Table
Output Current	See Table
Voltage Adjust Range	±10% typical adjustment by potentiometer
Voltage Tolerance	±1%
Set Up, Rise Time	800ms, 60ms at full load
Hold Up Time (typ.)	16ms at 230VAC, full load
Overload Protection	>105-150% of rated output power for more than 3 seconds, shutdown output with auto recovery >150% of rated output power or short circuit then constant current limiting. If output drops to 40% of rated output voltage then shutdown and auto recover for 5 times attempts. If fault remains for more than 5 attempts then latch off output and re-power on to recover.
Overvoltage Protection	See Table for values. Output latches off, recycle AC input to recover
Over Temperature Protection	Shuts down output, recovers automatically when temperature goes down
Auxiliary Power	+5V/0.3A (±3%)
Remote ON/OFF Control	External switch or NPN transistor to turn on/off
Power OK Signal	Open drain signal low when PSU turns on. Max. sink current 20mA, max drain voltage 40V
Operating Temp. Range	-25°C to +70°C. Above 50°C, derate linearly to 50% load at 70°C
Operating Humidity	20-90% RH non-condensing
Storage Temp. Range	-40°C to +85°C
Storage Humidity	10-95% RH non-condensing
Temperature Coefficient	±0.02%/°C (0-50°C)
Vibration	Compliance to IEC 68-2-6, IEC 68-2-64
Safety Standards	UL60950-1 2nd edition, TUV EN60950-1: 2006+A11 approved
Withstand Voltage	I/P-O/P: 3KVAC, I/P-FG: 1.5KVAC, O/P-FG: 0.5KVAC
Isolation Resistance	I/P-O/P, I/P-FG, O/P-FG: 100MΩ / 500VDC
EMI Conduction & Radiation	EN55022: 1998+A1 : 2000+A2 : 2003 Class B
Harmonic Current	EN61000-3-2: 2000+A2 : 2005 Class A, EN61000-3-3 : 1995+A1 : 2001
EMS Immunity	EN61000-4-2, 3, 4, 5, 6, 8, 11
Cooling	Internal fan
Dimensions	199(L) x 105(W) x 41(H) mm
Weight	1.1Kg

Notes:

1. All parameters NOT specifically mentioned are measured at 230VAC input, rated load and 25°C ambient temperature
2. Ripple and noise are measured at 20MHz bandwidth by using a 12" twisted pair wire terminated with a 0.1μF ceramic & 47μF electrolytic capacitors across the output
3. Derating is required at low input voltages. Below 100VAC, derate linearly to 80% load at 90VAC
4. Tolerance: includes set up tolerance, line regulation and load regulation
5. The power supply is considered a component which will be installed into a final equipment. The final equipment must be re-confirmed that it still meets EMC Directives

Email: sales@powersolve.com.tw

AC-DC Converter



www.powersolve.com.tw

Output Voltage and Current Ratings

MODEL	OUTPUT VOLTAGE	MAX OUTPUT CURRENT	OVERVOLTAGE PROTECTION	RIPPLE & NOISE	LINE REG.	LOAD REG.	POWER Max.	EFF.
PAK450-12	12V	37.5A	14.4-15.6V	150mV p-p	±0.5%	±0.5%	450W	89%
PAK450-24	24V	19A	28.8-31.2V	150mV p-p	±0.5%	±0.5%	456W	91%
PAK450-30	30V	15A	36.0-39.0V	150mV p-p	±0.5%	±0.5%	450W	91%
PAK450-36	36V	12.7A	43.2-46.8V	150mV p-p	±0.5%	±0.5%	457W	92%
PAK450-48	48V	9.5A	57.8-62.4V	150mV p-p	±0.5%	±0.5%	456W	93%

Mechanical & Connection Details

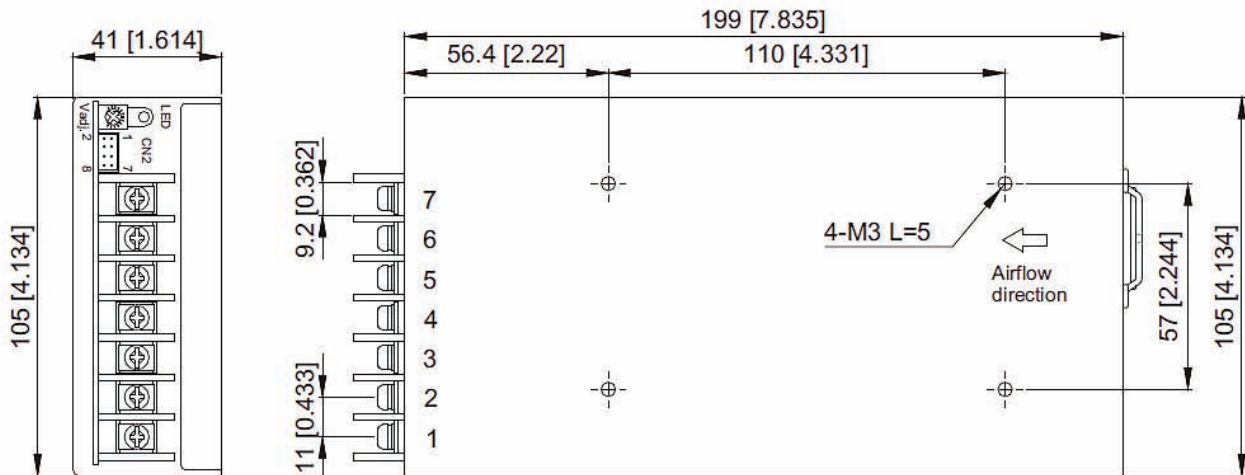

Connections

Pin	Function
1	Live
2	Neutral
3	Earth
4	-V out
5	-V out
6	+V out
7	+V out

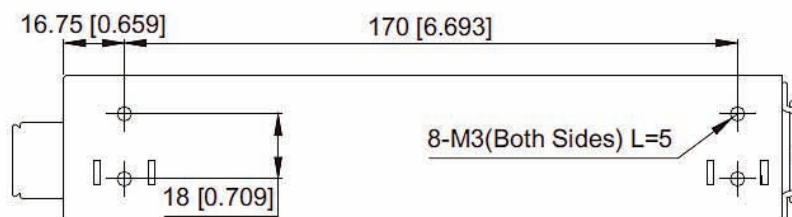

Function Description of CN2, Control Connector

Pin No.	Function	Description	Mating Housing	Terminal
1	AUX	+5V / 0.3A Auxiliary Power	JST	JST
2	GND	Ground		
3	POK	Power OK	PHDR-08VS	SPHD-002T-P05
4	EN-	Remote ON/OFF (-)		
5	GND	Ground		
6	EN+	Remote ON/OFF (+)		
7	VS+	Remote Voltage Sense (+)		
8	VS-	Remote Voltage Sense (-)		

AC-DC Converter



www.powersolve.com.tw

Derating Curves

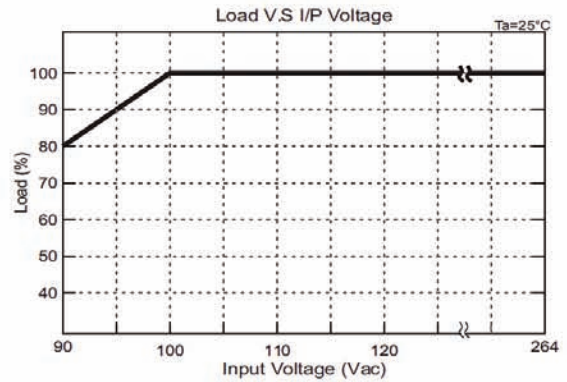
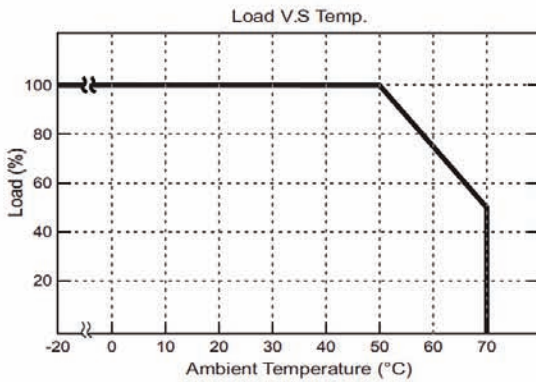

Peak Loading

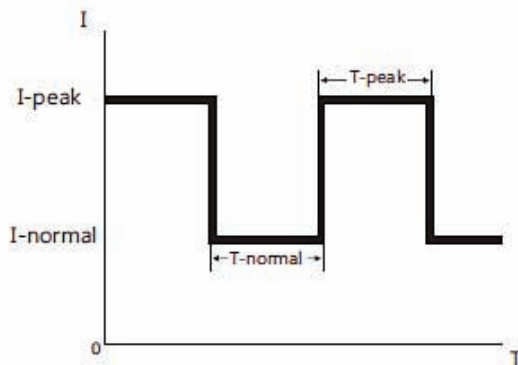

T_{PEAK} represents the period during which the output current is at 110% to 150% of nominal (shown as I_{PEAK}). Curve B shows the relationship between the percentage of peak current (I_{PEAK}) and the allowable duration (T_{PEAK}). If the peak current is taken for longer than the allowed duration indicated by curve B, the output current will drop to a constant limited current of 105% of nominal, then. The unit between peak currents (T_{NORMAL}) is dependant up on the output current drawn between the peaks (I_{NORMAL}) and curve A shows the relationship between the two. The higher the percentage of normal current (I_{NORMAL}) is of the nominal current, the longer the interval (T_{NORMAL}) before the next peak current can be drawn.

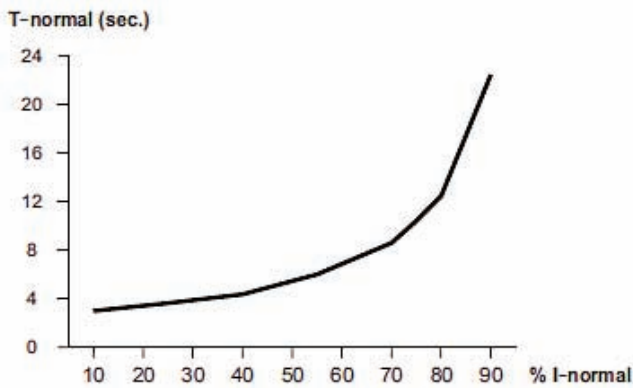

CURVE A

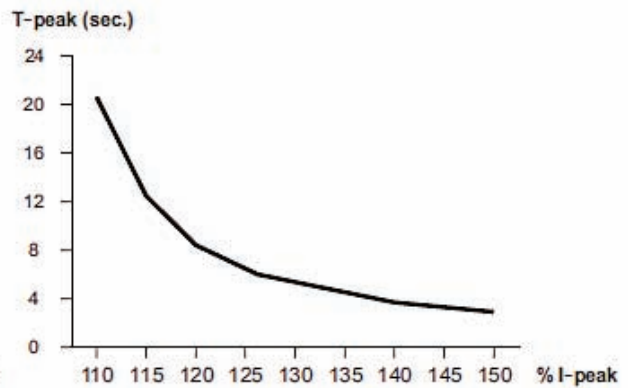

CURVE B

AC-DC Converter

Functions

Remote ON/OFF

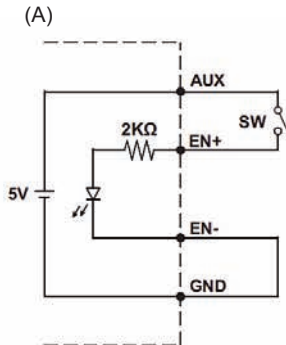

(A) Using internal 5V auxiliary source

SW	OFF	Power ON
	ON	Power OFF

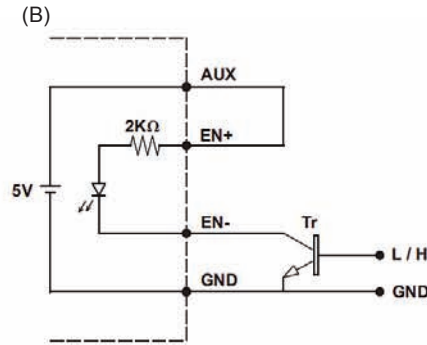

(B) ON/OFF control by NPN transistor

Tr	L	Power ON
	H	Power OFF

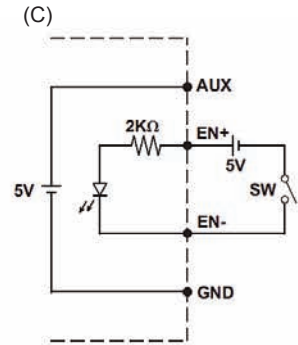

(C) Using external voltage source

SW	OFF	Power ON
	ON	Power OFF

Remote Sense

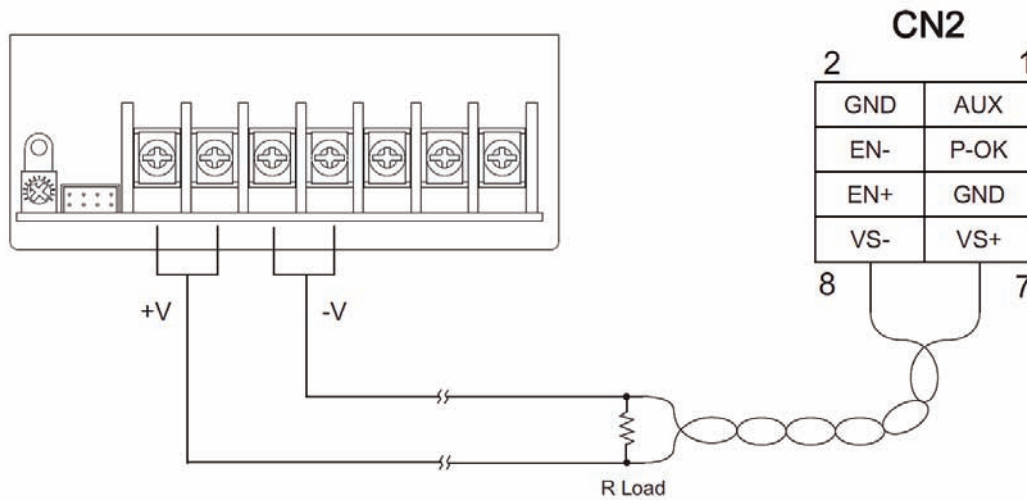

Power OK Signal & Auxiliary Output

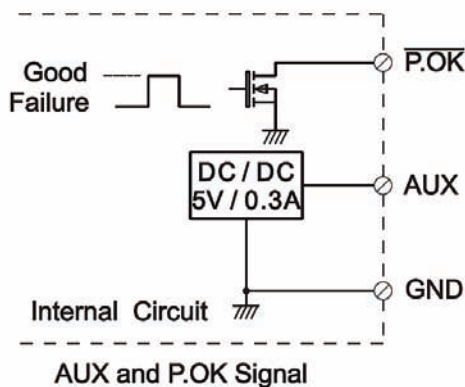

*Place an additional capacitor to have a better performance of auxiliary power operation.

*The grounding of "AUX" power should be connected to "GND" port. If "V-" is connected as Grounding, make sure to short the GND and V- ports.

