

AC-DC Converter

**POWER
SOLVE**

PAE1500 Series 1500W Active PFC Single Output

www.powersolve.com.tw

Features

- Universal AC Input with active PFC
- Programmable Output Voltage (0%-105%)
- Programmable Output Current (0%-105%)
- Constant Current Limit
- +5V/0.5A or +9V/0.3A Auxiliary Output
- Forced current sharing for parallel operation
- Power OK signal
- Remote ON/OFF, Remote Sense function
- OVP, OLP, OTP, Fan Failure Protections
- Global Control via RS232
- Remote Setting multiple PSU via RS232, RS485 & I²C



Electrical Specification

Input Voltage	90-264VAC full range, 47-63Hz / 127-370VDC. Below 100VAC, derate load linearly to 80% at 90VAC.
Power Factor	0.95 at 230VAC / 0.99 at 115VAC at full load
AC Input Current (typ.)	18A at 115VAC / 9A at 230VAC
Inrush Current	30A at 115VAC / 45A at 230VAC
Leakage Current	<2.5mA at 240VAC
Output Voltage	See Table
Output Current	See Table
Voltage Tolerance	±2%
Voltage Adjust Range	±5.0% typical adjustment by potentiometer
Overload Protection	>105% of rated output power. Protection type: Constant current limiting
Overvoltage Protection	Variable OVP, 120% ±7% of Vout. Output latches off, recycle AC input to recover or inhibit
Over Temperature Protection	Shuts down output, recovers automatically (85°C ±5°C detected on heatsink on secondary side)
Auxiliary Power	+5V/0.5A or +9V/0.3A auxiliary output selected by user
Remote ON/OFF Control	External switch or NPN transistor to turn on/off
Power OK Signal	Open drain signal low when PSU turns on. Max. sink current 20mA, max drain voltage 40V
Output Voltage Programming	Adjustment of output voltage between 0-105% of rated output
Output Current Programming	Adjustment of output current between 0-105% of rated output
Operating Temperature Range	-20°C to +60°C. Above 50°C, derate linearly to 60% load at 60°C
Operating Humidity	20-90% RH non-condensing
Storage Temperature Range	-40°C to +85°C
Storage Humidity	10-95% RH non-condensing
Temperature Coefficient	±0.02%/°C (0-50°C)
Vibration	10-500Hz, 2G 10 min./1 cycle, period 60min. each along X, Y & Z axes. Compliance to IEC68-2-6, IEC68-2-64
Safety Standards	Certified to UL60950-1, EN60950-1
Withstand Voltage	I/P-O/P: 3KVAC (4242VDC), I/P-FG: 1.5KVAC (2121VDC), O/P-FG: 0.5KVAC (707VDC)
Isolation Resistance	I/P-O/P, I/P-FG, O/P-FG: 100MΩ / 500VDC
EMI Conduction & Radiation	Certified to EN55022, EN61204-3, EN61000-6-3
Harmonic Current	Certified to EN61000-3-2, EN61000-3-3
EMS Immunity	Certified to EN55024, EN61204-3, EN61000-6-1, EN61000-4-2, -3, -4, -5, -6, -8, -11
Cooling	Internal fan controlled by power rating & temperature, allow 50mm clearance at each end for airflow
Dimensions	280(L) x 127(W) x 63.5(H) mm
Weight	2.6Kg

Notes:

1. All parameters NOT specifically mentioned are measured at 230Vac input, rated load and 25°C ambient temperature
2. Ripple and noise are measured at 20MHz bandwidth by using a 12" twisted pair wire terminated with a 0.1µF ceramic & 47µF electrolytic capacitors across the output
3. Tolerance includes set up tolerance, line regulation and load regulation
4. Derating is required at low input voltages. Below 100Vac, derate linearly to 80% load at 90Vac
5. When parallel connected, only one unit may operate if the total output load is less than 5% of rated load
6. The power supply is considered a component which will be installed into a final equipment. The final equipment must be re-confirmed that it still meets EMC Directives

Email: sales@powersolve.com.tw

AC-DC Converter



www.powersolve.com.tw

Output Voltage and Current Ratings

MODEL	OUTPUT VOLTAGE	MAX OUTPUT CURRENT	RIPPLE & NOISE	LINE REG.	LOAD REG.	POWER Max.	EFF.
PAE1500-12	12V	125A	120mV p-p	±1%	±1%	1500W	89%
PAE1500-15	15V	100A	150mV p-p	±1%	±1%	1500W	90%
PAE1500-24	24V	62.5A	240mV p-p	±1%	±1%	1500W	92%
PAE1500-30	30V	50A	300mV p-p	±1%	±1%	1500W	92%
PAE1500-36	36V	41.7A	360mV p-p	±1%	±1%	1500W	92%
PAE1500-48	48V	31.3A	480mV p-p	±1%	±1%	1500W	92%
PAE1500-60	60V	25A	600mV p-p	±1%	±1%	1500W	93%

Mechanical & Connection Details

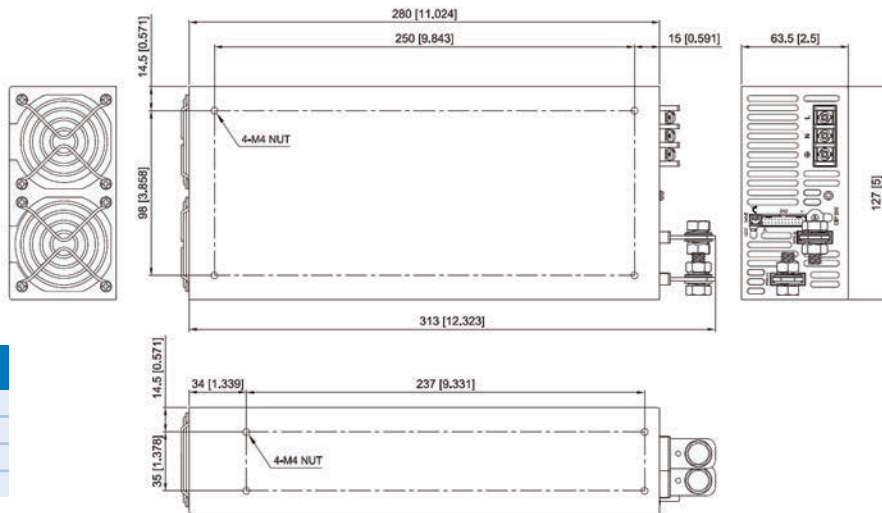

Connections

Pin	Function
1	Live
2	Neutral
3	Earth

Function Description of CN5, Control Connector

Pin No.	Function	Description	Mating Housing	Terminal
1	N.C.	For RS232 Receiver Function		
2	N.C.	For RS232 Transmission Function		
3, 7, 14	AUX	+5V/0.5A or +9V/0.3A Auxiliary power		
4, 8, 10, 12, 16, 20	GND	Ground		
5	SCL	Serial Clock used in the I ² C interface		
6	SDA	Serial Data used in the I ² C interface		
9	VCI	V Program		
11	ACI	I Program	JST	JST
13	EN+	Inhibit ON/OFF +		
15	EN-	Inhibit ON/OFF -	PHDR-24VS	SPHD-002T-P0.5
17	PAR	Parallel operation current share		
18	VSET	Aux Output Set		
19	POK	Power OK		
21	VS-	Remote Sense -		
22	VO-	Negative Output Voltage		
23	VS+	Remote Sense +		
24	VO+	Positive Output Voltage		

LED Status

LED Colour	LED Signal	Status
Green LED	Solid	Power OK (Local mode)
Orange LED	Solid	Power OK (Remote mode)
Green LED	Slow Blink	Power Standby
	Fast Blink	Over Voltage Protection (OVP)
	Solid	Over Load Protection (OLP)
Red LED	Slow Blink	Over Temperature Protection (OTP)
	Intermittent Blink	Fan Failure
	Interlace Blink	Power Failure

AC-DC Converter



www.powersolve.com.tw

De-rating Curve

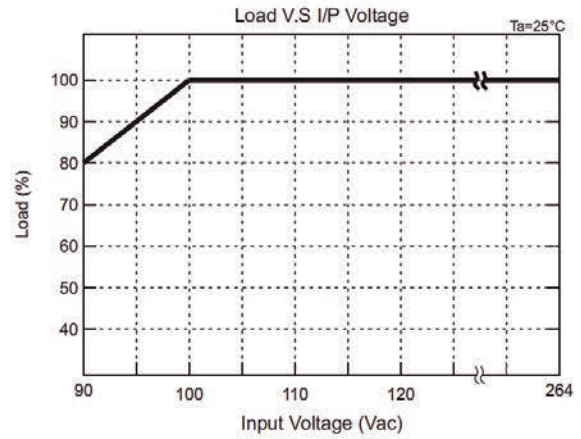
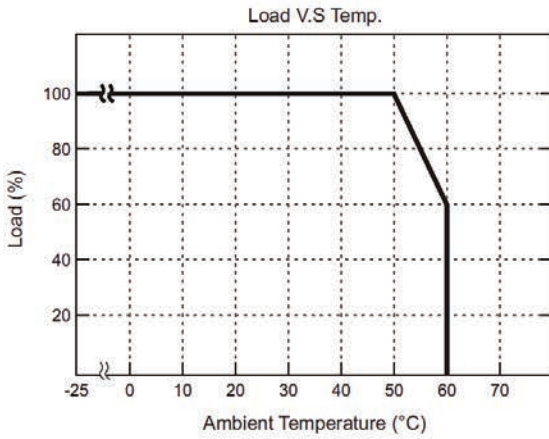

Programming Input

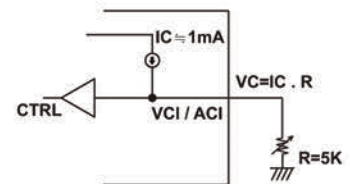
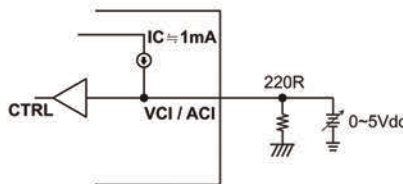
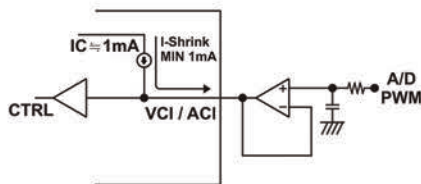
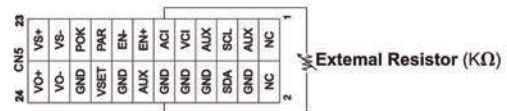
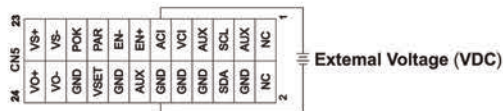
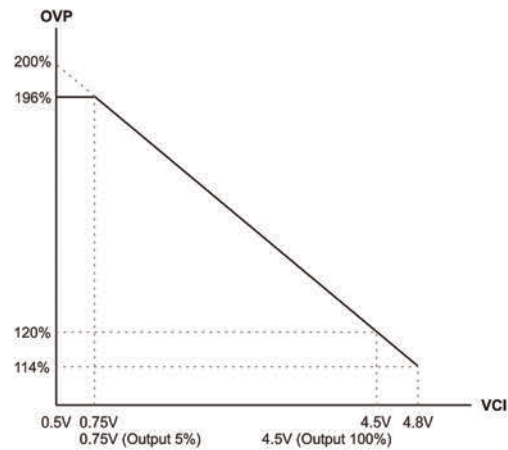
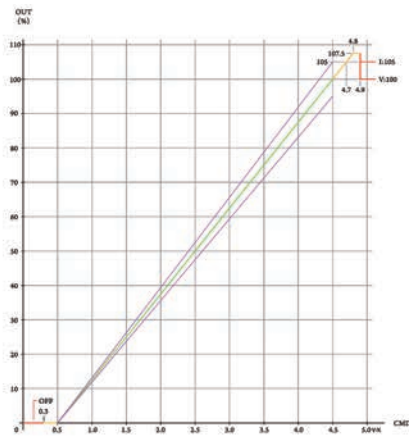

AC-DC Converter



www.powersolve.com.tw

Remote ON/OFF

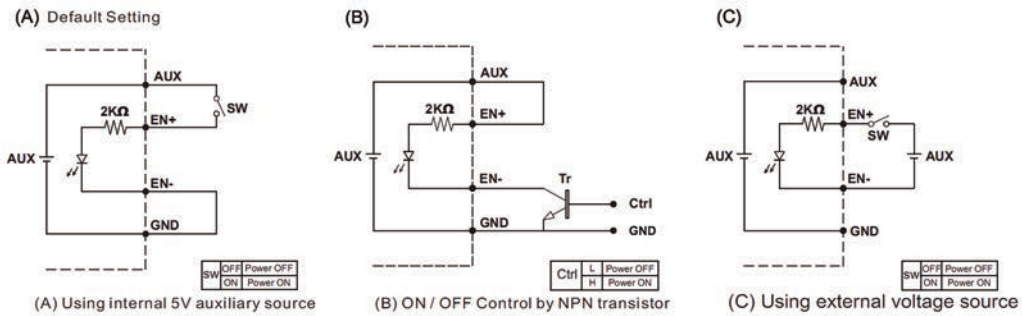

Power OK Signal

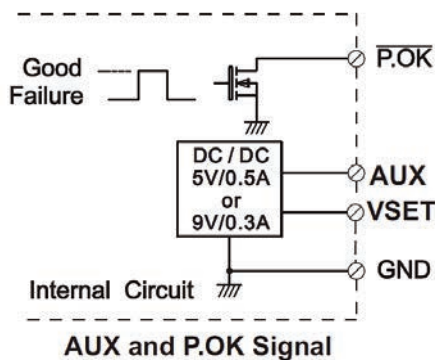

*Place an additional capacitor to have a better performance of auxiliary power operation.

*The grounding of "AUX" power should be connected to "GND" port. If "V-" is connected as Grounding, make sure to short the GND and V- ports.

VSET	Open(Default Setting)	5V
	Short To GND	9V

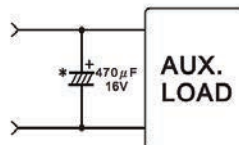

Functions

1. Remote Sense

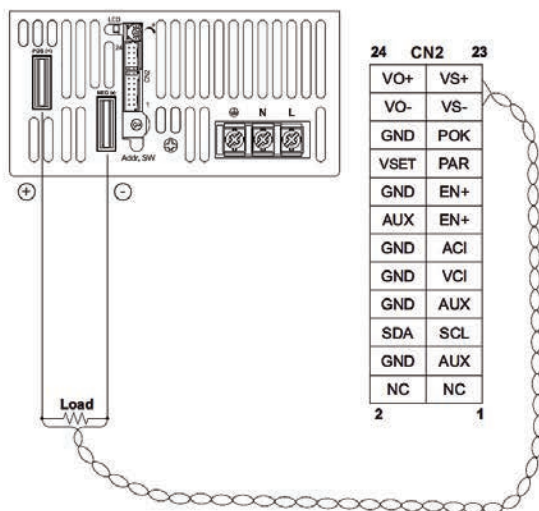

2. Local Sense (Default setting)

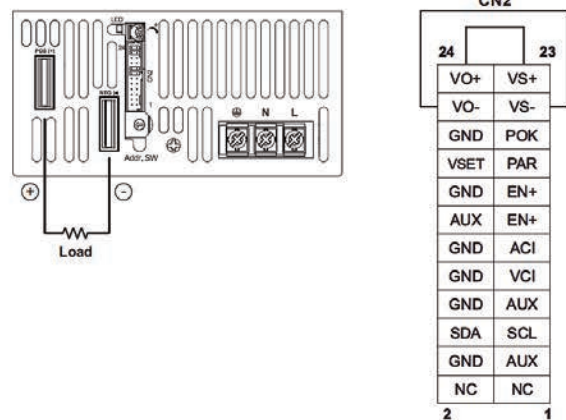

AC-DC Converter



www.powersolve.com.tw

3. Current Sharing with Remote Sensing

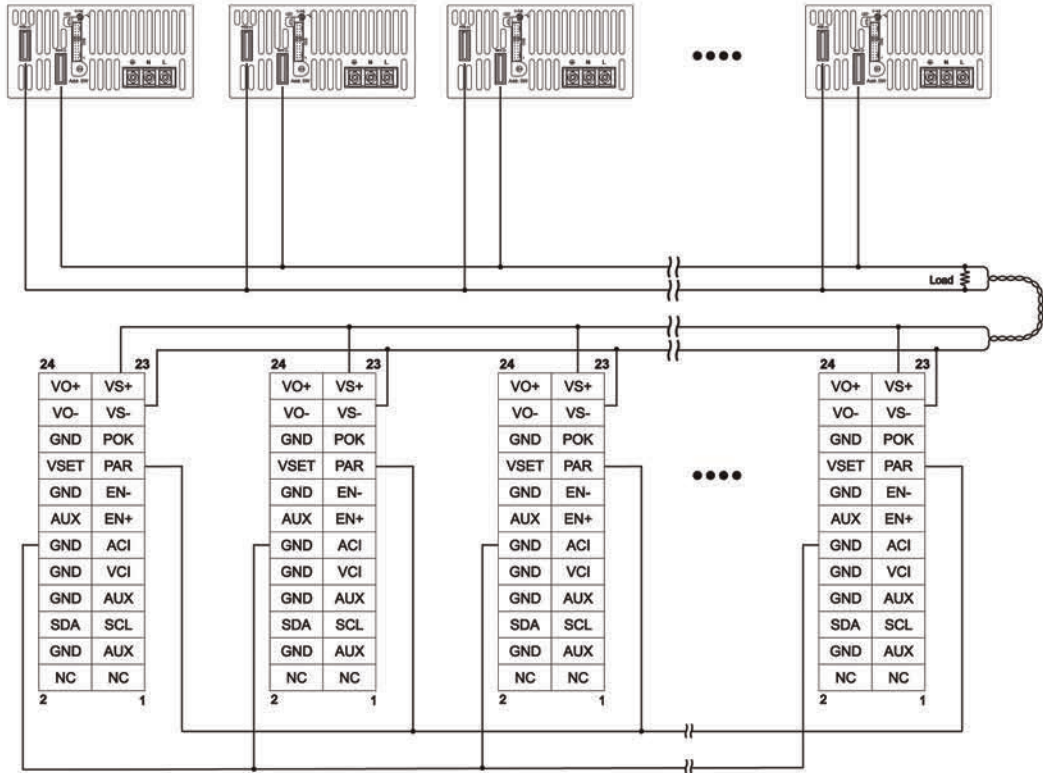

4. Current Sharing with Local Sensing

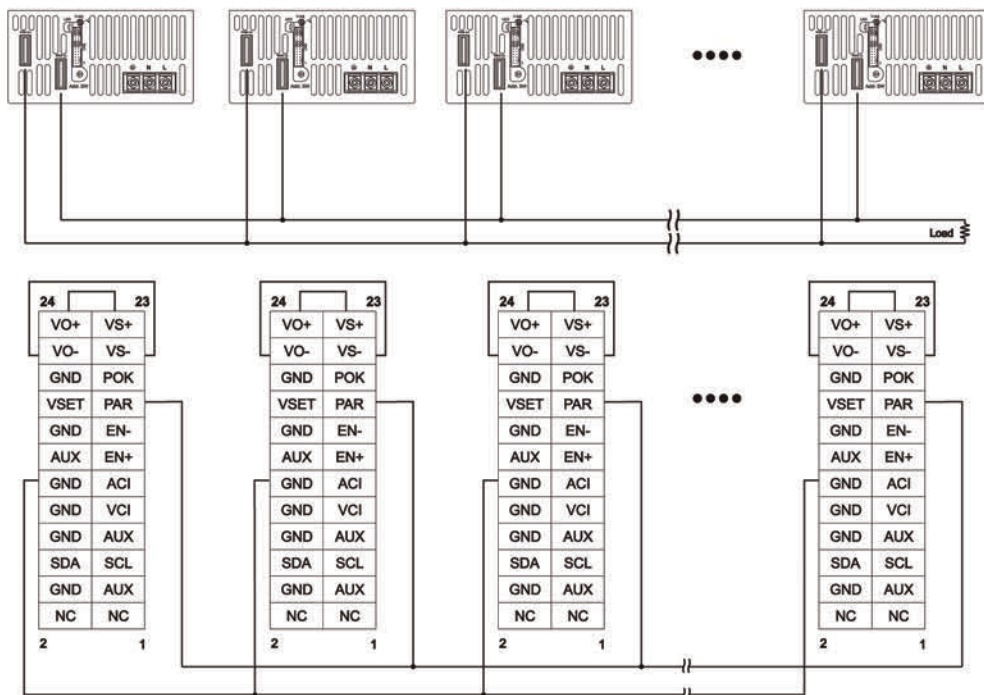

AC-DC Converter

**POWER
SOLVE**

www.powersolve.com.tw

Installation Instructions

1. Mounting Directions

1-1 Recommended standard mounting methods:

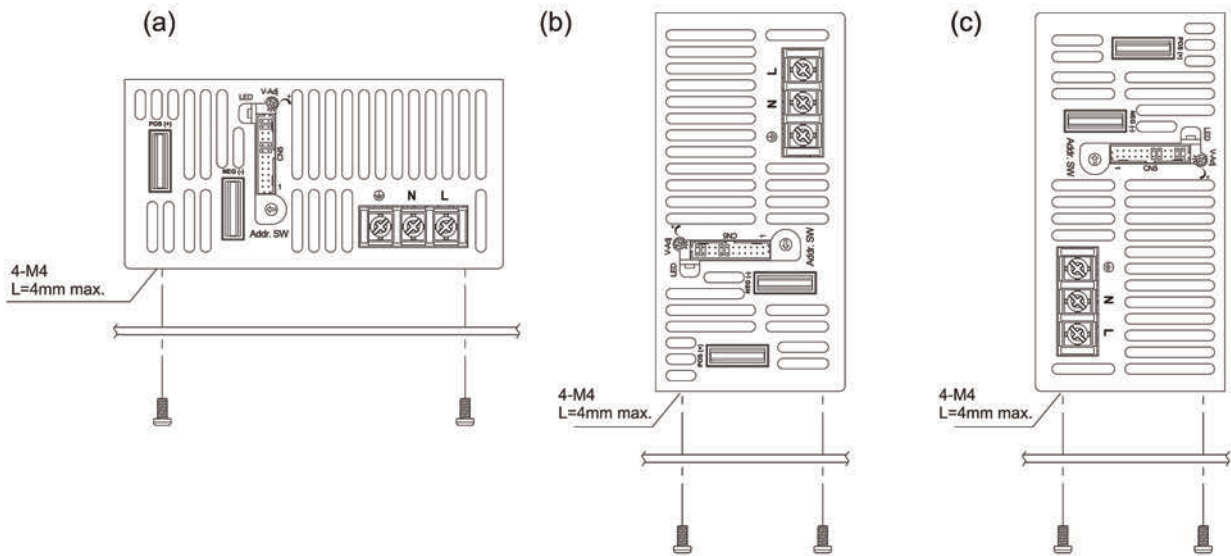

2. Mounting Method

2-1 There are ventilating holes on the front and back side panels, do not obstruct; allow 50mm at least for air flow.

2-2 The Maximum allowable penetration of screw is 4mm. Incomplete threading should not be penetrated.

2-3 Recommended the torque of mounting screw:
M4 screw: 1.27N • m (13.0kgf • cm)

