

- NOTE:
- MATERIAL:
 - INSULATOR: HIGH TEMPERATURE PLASTIC UL 94 V-0;
 - CONTACT: COPPER ALLOY
 - SHELL: STAINLESS STEEL
 - ELECTRICAL CHARACTERISTICS:
 - CONTACT RESISTANCE: 40mΩ Max FOR INITIAL, 10mΩ CHANGE AFTER TEST. MEASURE AT 20mV, 100mA.
 - CONTACT CURRENT RATINGS: 3A FOR VBUS PIN, 1.25A FOR VCONN PIN.
 - DIELECTRIC WITHSTANDING VOLTAGE: 100V AC R.M.S.
 - INSULATION RESISTANCE 100MΩ Min
 - OPERATING TEMPERATURE: -40°C ~ 85°C
 - MECHANICAL CHARACTERISTICS:
 - MATING FORCE: 5~20 N.
 - UNMATED FORCE: 6~20N AFTER TEST
 - DURABILITY: 10,000 CYCLES
 - PLATING:
 - TERMINAL CONTACT: (SEE TAB) GOLD PLATING ALL OVER 50u" NICKEL AND 80u" Tin ALL OVER 50u" NICKEL ON SOLDER AREA
 - SHELL: 50u" NICKEL ALL OVER.

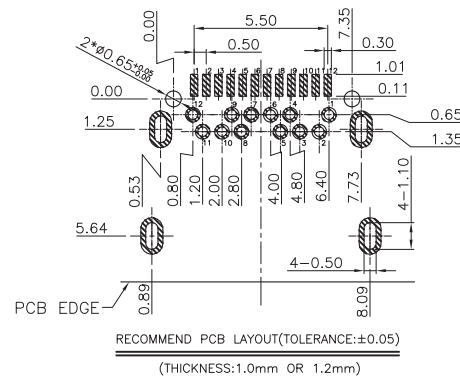
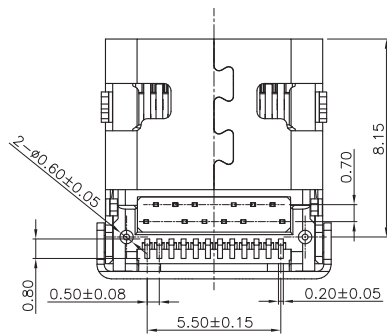
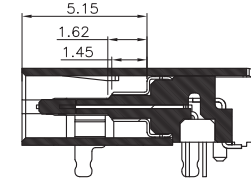
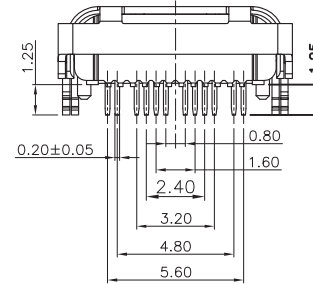
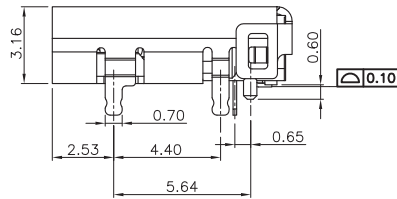
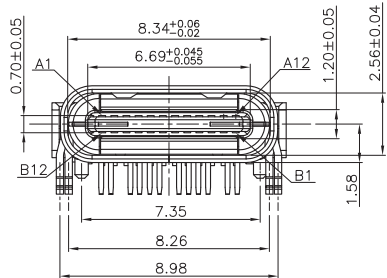

PIN	SIGNAL NAME	PIN	SIGNAL NAME
A1	GND	B12	GND
A2	TX1+	B11	RX1+
A3	TX1-	B10	RX1-
A4	VBUS	B9	VBUS
A5	CC1	B8	SBU2
A6	D+	B7	D-
A7	D-	B6	D+
A8	SBU1	B5	CC2
A9	VBUS	B4	VBUS
A10	RX2-	B3	TX2-
A11	RX2+	B2	TX2+
A12	GND	B1	GND

凱帛企業有限公司
KABO ENTERPRISE CO., LTD.

DESCRIPTION(內容):
USB C母 SMT+DIP R/A TYPE 24PIN
LCP (黑膠) 不銹鋼 板上 3.1版

PART NO:
(料 號) **USB-C-1052-2493N**
DWG NO(圖號):

DRAWN(製圖):
CHECKED(確認):
APPROVAL(核准):

GENERAL TOLERANCE:
(公差)
.X ±0.30
.XX ±0.20
.XXX ±0.10
SCALE(比例):
1:XX

REV:
A
UNIT:
mm
SIZE:
A4
SHEET:
1/1

REV	DESCRIPTION	DATE
1		2020.01.03
2		
3		
4		

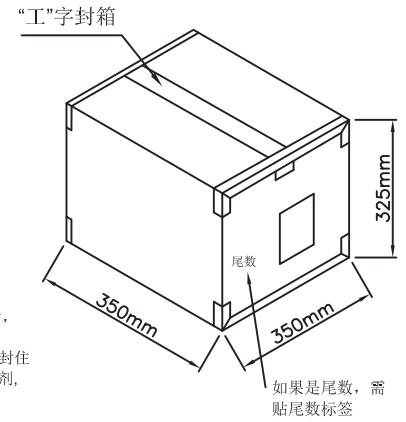
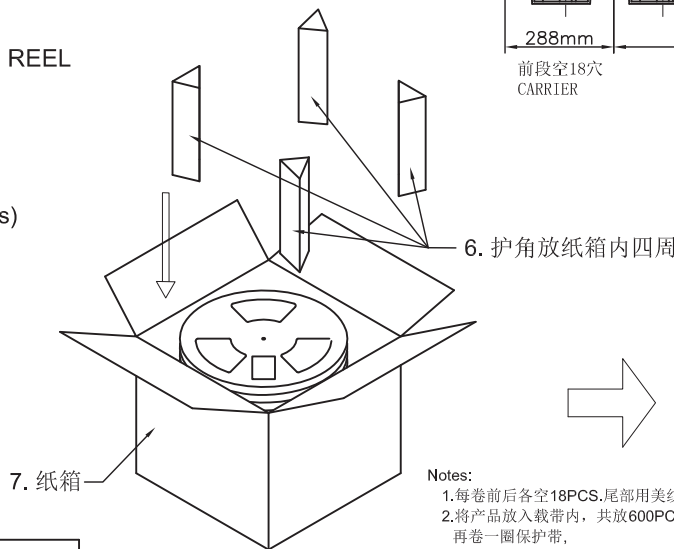
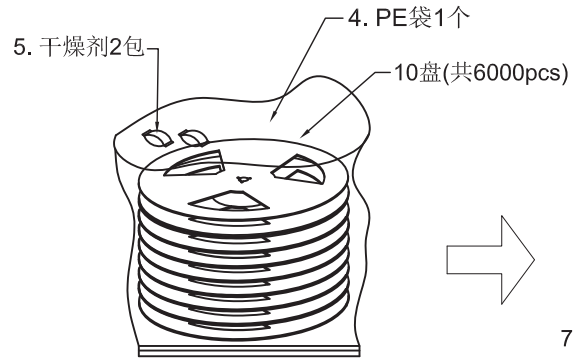
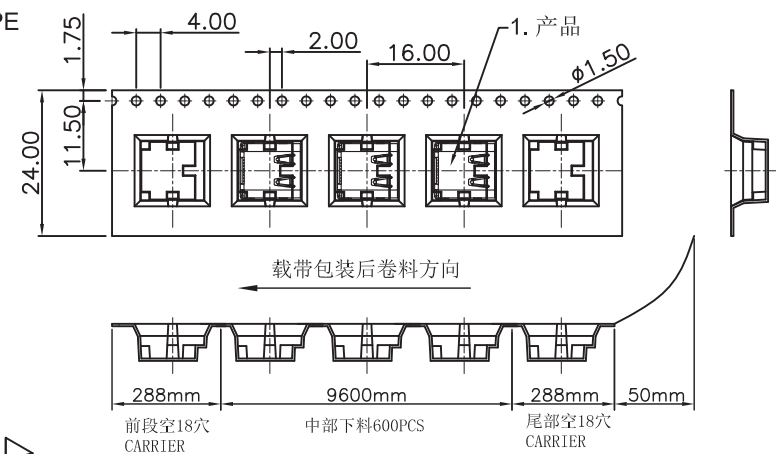
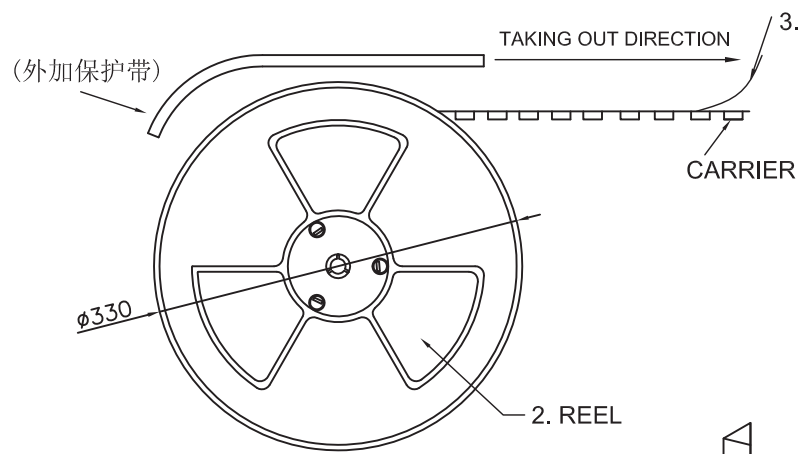

7	纸箱	01Y24XK	双坑K=K 350*350*325mm	1PCS
6	三角柱	01Y07XK	30.5*29cm	4PCS
5	干燥剂	DE-01	——	2PCS
4	PE袋	01J02WP	71*79.5cm	1PCS
3	COVER TAPE	01R09WP	21.0mm (自粘带)	若干
2	REEL	01R12ZS	24.0mm (黑色载带)	10R
1	产品	01FS24SXN226RZL	——	6K
序号	品名	料号	规格(mm)	用量(PCS)

包装数量	净重	毛重
6000Pcs/箱		

- Notes:
1. 每卷前后各空18PCS.尾部用美纹胶纸封住.
 2. 将产品放入载带内, 共放600PCS,放满盘后,再卷一圈保护带, 保护带最后重叠约50mm, 用美纹胶纸将其封住
 3. 每10卷盘装入一个防水袋, 再放入2包干燥剂, 然后放入1个外箱内; 纸箱内四周放护角;
 4. 在搬运过程中要轻拿轻放.
 5. 在运输中不可堆放过多,不可有重压现象.
 6. 跌落测试条件:
成品箱子从1.5米高自由落体;(三棱六面一角)检验项目:
1. 产品不可跑出下带凹槽.
2. 产品不可有摔伤,变形.
3. 外箱及内包装材料不可严重破损.

凱帛企業有限公司
KABO ENTERPRISE CO., LTD.

DESCRIPTION(內容):
USB C母 SMT+DIP R/A TYPE 24PIN
LCP (黑膠) 不銹鋼 板上 3.1版

PART NO:
(料 號) USB-C-1052-2493N

DWG NO(圖號):

DRAWN(製圖):

CHECKED(確認):

APPROVAL(核准):

GENERAL TOLERANCE:
(公差)

.X ±0.30
.XX ±0.20
.XXX ±0.10

SCALE(比例):
1:XX

REV: A

UNIT: mm

SIZE: A4

SHEET: 1/1

REV	DESCRIPTION	DATE
1		2020.01.03
2		
3		
4		