

### Specifications

Current Rating	: 1 Amp
Insulator Resistance	: 1000 Megohms Min.
Contact Resistance	: 20 m ohms max.
Dielectric Withstanding	: AC 500 V
Operating Temperature	: -40°C ~ +105°C
Soldering Temperature	: 260°C for 3~5sec Max.
Contact Material	: Phosphor Bronze
Insulator Material	: Polyester, UL 94V-0
Standard	: Nylon-6T/NL-9T/LCP
Finish	: Gold Plated
Standard	: Gold Flash all over

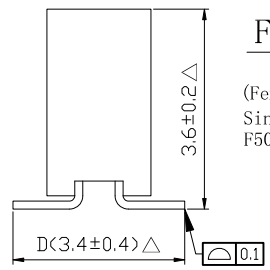

Series	Connector Type	Contact Plating	Material	Pin Length	mm	Number of Contacts	Other
F504	X	X	X	-	DXXX	-XX	-XT
(Female Header Single Row) F504 (1.27 H: 3.4)	M: SMT Type	G: Gold Flash T: Tin Plated A: 10U"Gold B: 15U"Gold C: 20U"Gold ©Duplex Plating D: Gold Flash/Tin (Standard:G)	N: Nylon-6T NL: Nylon-9T C: LCP (Standard: N)	M-D D034		(02 TO 40 Contacts)	AT: TYPE A BT: TYPE B

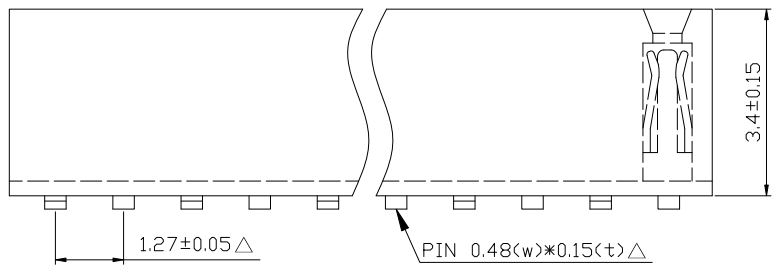

DESCRIPTION(內容): <b>1.27mm Female Header H:3.4 W:2.2 SMT (RoHS)</b>
PART NO: (料號) <b>F504-MG_D034-XX-XT</b>
DWG NO(圖號):

DRAWN(製圖): 鄧文廣
CHECKED(確認): 王建平
APPROVAL(核准): 鄧文廣

GENERAL TOLERANCE: (公差)	.X .XXXX .XX .X° .XXX .XX°
SCALE(比例): XX:XX	⊕

REV: <b>A/1</b>	REV	DESCRIPTION	DATE
UNIT: <b>mm</b>	1	△圖面中有此符號表示重點尺寸	2017.02.23
SIZE: <b>A4</b>	2		
SHEET: <b>1/1</b>	3		
	4		

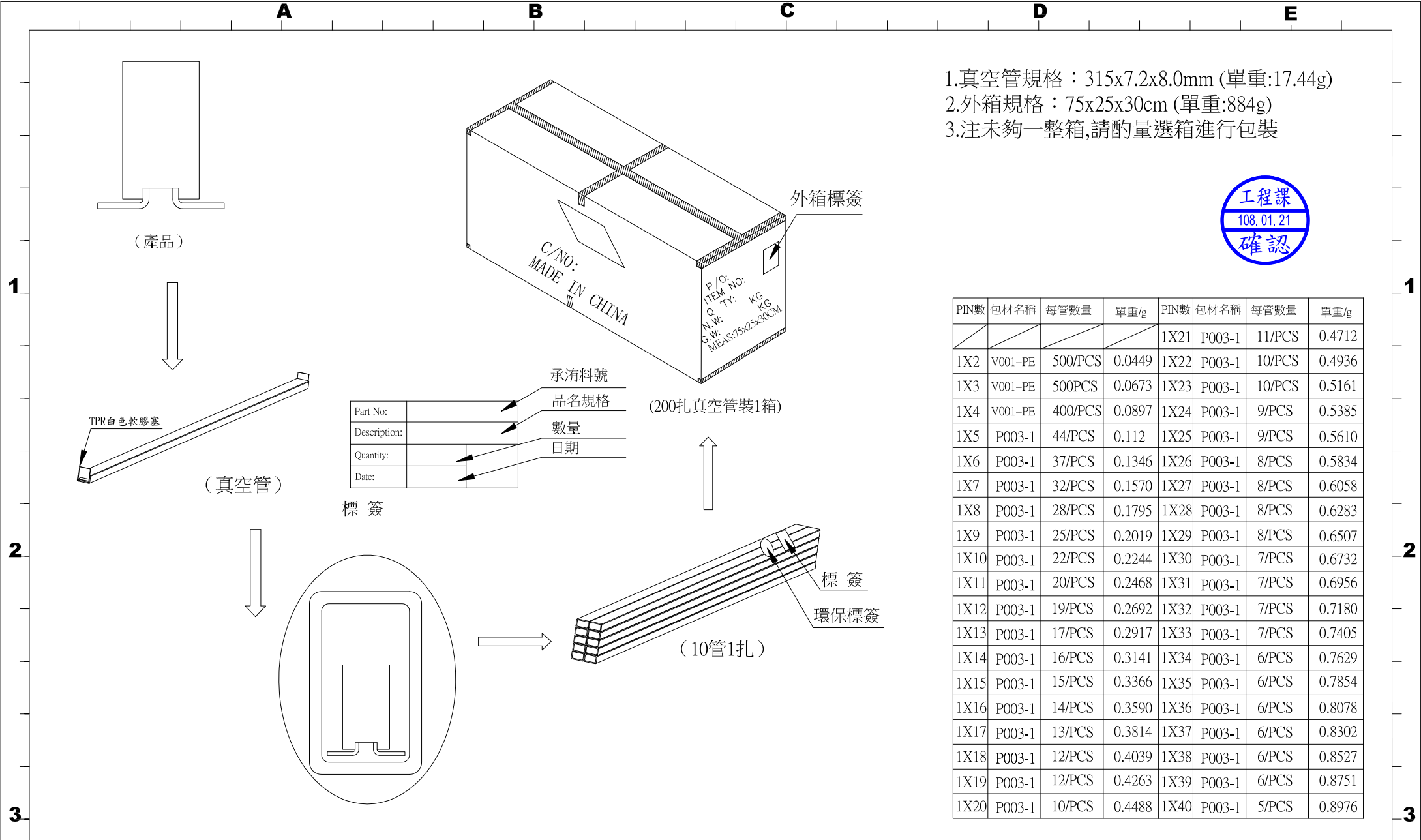

- 1.真空管規格：315x7.2x8.0mm (單重:17.44g)
- 2.外箱規格：75x25x30cm (單重:884g)
- 3.注未夠一整箱,請酌量選箱進行包裝



PIN數	包材名稱	每管數量	單重/g	PIN數	包材名稱	每管數量	單重/g
1X2	V001+PE	500/PCS	0.0449	1X21	P003-1	11/PCS	0.4712
1X3	V001+PE	500/PCS	0.0673	1X22	P003-1	10/PCS	0.4936
1X4	V001+PE	400/PCS	0.0897	1X23	P003-1	10/PCS	0.5161
1X5	P003-1	44/PCS	0.112	1X24	P003-1	9/PCS	0.5385
1X6	P003-1	37/PCS	0.1346	1X25	P003-1	9/PCS	0.5610
1X7	P003-1	32/PCS	0.1570	1X26	P003-1	8/PCS	0.5834
1X8	P003-1	28/PCS	0.1795	1X27	P003-1	8/PCS	0.6058
1X9	P003-1	25/PCS	0.2019	1X28	P003-1	8/PCS	0.6283
1X10	P003-1	22/PCS	0.2244	1X29	P003-1	8/PCS	0.6507
1X11	P003-1	20/PCS	0.2468	1X30	P003-1	7/PCS	0.6732
1X12	P003-1	19/PCS	0.2692	1X31	P003-1	7/PCS	0.6956
1X13	P003-1	17/PCS	0.2917	1X32	P003-1	7/PCS	0.7180
1X14	P003-1	16/PCS	0.3141	1X33	P003-1	7/PCS	0.7405
1X15	P003-1	15/PCS	0.3366	1X34	P003-1	6/PCS	0.7629
1X16	P003-1	14/PCS	0.3590	1X35	P003-1	6/PCS	0.7854
1X17	P003-1	13/PCS	0.3814	1X36	P003-1	6/PCS	0.8078
1X18	P003-1	12/PCS	0.4039	1X37	P003-1	6/PCS	0.8302
1X19	P003-1	12/PCS	0.4263	1X38	P003-1	6/PCS	0.8527
1X20	P003-1	10/PCS	0.4488	1X39	P003-1	6/PCS	0.8751
				1X40	P003-1	5/PCS	0.8976

Part No:		承消料號
Description:		品名規格
Quantity:		數量
Date:		日期

(200扎真空管裝1箱)

標籤  
環保標籤

(10管1扎)



DESCRIPTION(內容)  
**1.27mm Female Header H:3.4 W:2.2 SMT (RoHS)**

PART NO:  
(料號) **F504-MG\_-D034-XX-XT(包裝圖)**

DWG NO(圖號):

DRAWN(製圖): 黃玉美  
CHECKED(確認): 鄧文广  
APPROVAL(核准): 鄧文广

GENERAL TOLERANCE:  
(公差)  
.X .XXXX  
.XX .X°  
.XXX .XX°

SCALE(比例): 1:XX

REV: **A/2**  
UNIT:  
SIZE: **A4**  
SHEET: **1/1**

REV	DESCRIPTION	DATE
1	修改1*7P的數量	2008.12.16
2	更改短管子	2010.07.16
3		
4		