

P.C.B LAYOUT  
TOP VIEW

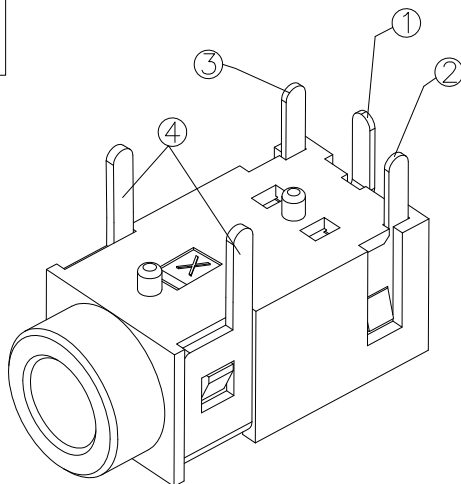

SPECIFICATION

1. Rating : DC 30V 0.5A;
2. Contact resistance:  $\leq 0.03 \Omega$ ;
3. Insulation resistance:  $\geq 100M \Omega$  (DC250V);
4. Withstand voltage: 500V AC ;
5. Insertion and extraction force: 3-30N;
6. life test: 5,000 cycles.

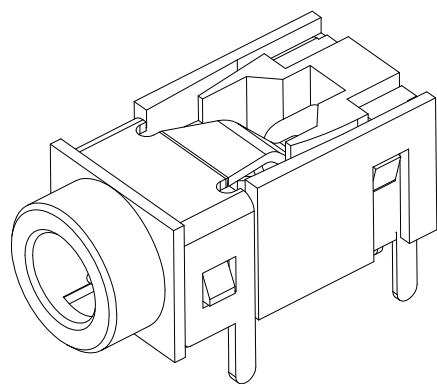
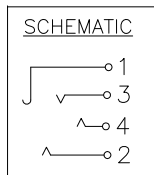
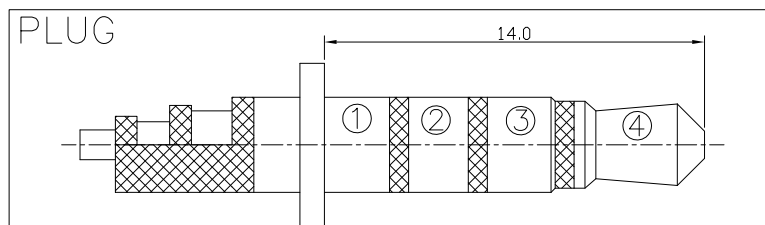

5	HOUSING	1	PBT	—	—
4	4# CONTACT FOOT	1	PHOSPHOR BRONZE	—	Sn-Plating
3	3# CONTACT FOOT	1	BRASS	—	Sn-Plating
2	2# CONTACT FOOT	1	PHOSPHOR BRONZE	—	Sn-Plating
1	1# CONTACT FOOT	1	PHOSPHOR BRONZE	—	Sn-Plating
NO.	DESCRIPTION	QTY	MATERIAL	COLOR	REMARK