

SPECIFICATIONS
 Current rating : 0.7A AC, DC
 Voltage rating : 30V AC, DC
 Temperature range : -25°C ~ +85°C
 Contact resistance : 20mΩMax
 Insulation resistance : 100MΩMin
 Withstanding voltage : 200 V AC/minute
 Finished : Matte Tin-plated
 Housing Material : Nylon-6T, UL94 V-0

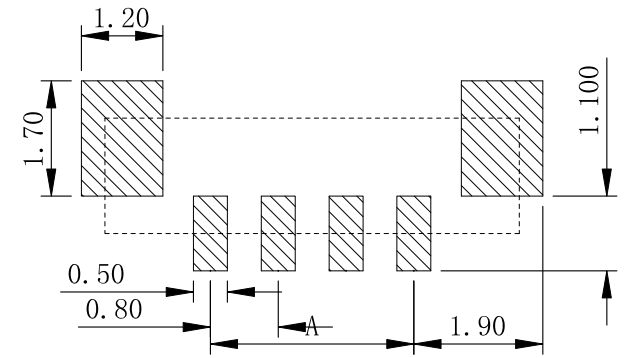

P.C.B LAYOUT



Circuits	Dimension mm		Circuits	Dimension mm	
	A	B		A	B
			12PIN	8.80	11.80
02PIN	0.80	3.80	13PIN	9.60	12.60
03PIN	1.60	4.60	14PIN	10.40	13.40
04PIN	2.40	5.40	15PIN	11.20	14.20
05PIN	3.20	6.20	16PIN	12.00	15.00
06PIN	4.00	7.00	17PIN	12.80	15.80
07PIN	4.80	7.80	18PIN	13.60	16.60
08PIN	5.60	8.60	19PIN	14.40	17.40
09PIN	6.40	9.40	20PIN	15.20	18.20
10PIN	7.20	10.20	21PIN	16.00	19.00
11PIN	8.00	11.00	22PIN	16.80	19.80



DESCRIPTION(內容):
0.8MM WAFER 180° SMT TYPE
 (RoHS)
PART NO: CC0801-W08-XX
DWG NO(圖號):

DRAWN(製圖): 王建平
CHECKED(確認): 鄧文廣
APPROVAL(核准): 鄧文廣
GENERAL TOLERANCE:
 .X ±0.08
 .XX ±0.05
 .XXX ±0.03
SCALE: 1:1

REV	DESCRIPTION	DATE
1	△此符號表示重點管控尺寸	2008.03.12
2	更正Layout圖	2009.07.16
3	變更電流大小	2012.10.17
4	修改PCB板示意图	2012.10.17

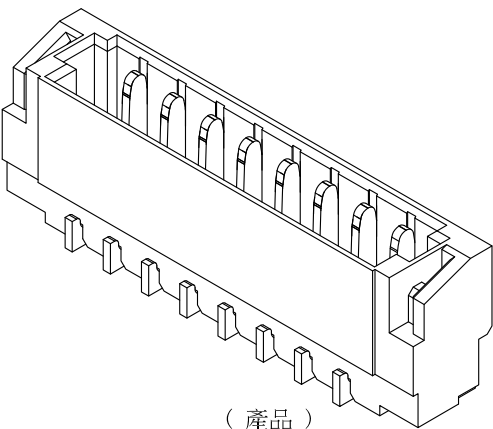

(產品)

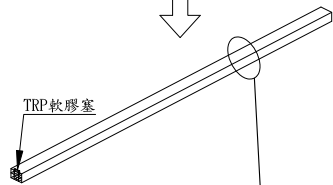

TRP軟膠塞

(真空管)

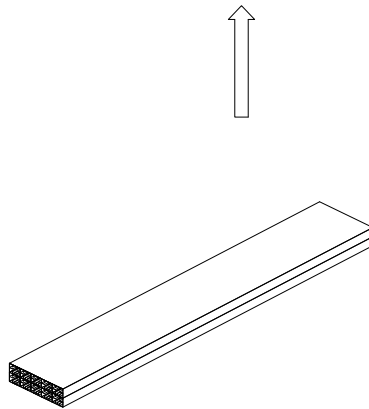
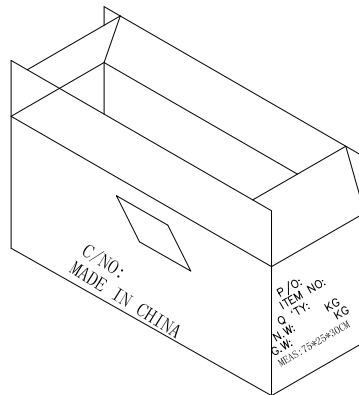
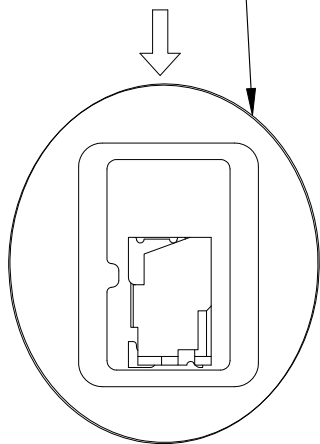

(10管1扎)

1. 真空管規格: 325x5.15x3.8mm (2.3g)
2. 外紙箱規格: 75x25x30cm (830g)
3. 未夠一箱請酌量選箱進行包裝

PIN數	包材名稱	每管數量	單重	PIN數	包材名稱	每管數量	單重
				1*12	P090-1	26/PCS	0.15144
1*02	PE15*15+V017	3000/PCS	0.02524	1*13	P090-1	24/PCS	0.16406
1*03	P090-1	66/PCS	0.03786	1*14	P090-1	23/PCS	0.17668
1*04	P090-1	56/PCS	0.05048	1*15	P090-1	21/PCS	0.18930
1*05	P090-1	49/PCS	0.06310	1*16	P090-1	20/PCS	0.20192
1*06	P090-1	43/PCS	0.07572	1*17	P090-1	19/PCS	0.21454
1*07	P090-1	39/PCS	0.08834	1*18	P090-1	18/PCS	0.22716
1*08	P090-1	35/PCS	0.10096	1*19	P090-1	17/PCS	0.23978
1*09	P090-1	32/PCS	0.11358	1*20	P090-1	17/PCS	0.25240
1*10	P090-1	30/PCS	0.12620	1*21	P090-1	16/PCS	0.26502
1*11	P090-1	28/PCS	0.13882	1*22	P090-1	15/PCS	0.27764



DESCRIPTION(內容):
0.8MM WAFER 180° SMT TYPE
 (RoHS)

PART NO:
 (料號) **CC0801-W08-XX**(包裝圖)

DWG NO(圖號):

DRAWN(製圖):
 黃炳秋
 CHECKED(確認):
 黃炳秋

APPROVAL(核准):
 鄧文廣

GENERAL TOLERANCE:
 (公差)

.X .XXXX
 .XX .X°
 .XXX .XX°

SCALE(比例):
 1:XX



REV:
A/6
 UNIT:
mm
 SIZE:
A4
 SHEET:
2/2

REV	DESCRIPTION	DATE
2	更改管子长度	2009.07.03
3	更改管子规格	2011.01.05
5	更改真空管P090-1	2014.03.26
6	更改2Pin包裝方式及數量	2015.03.18